

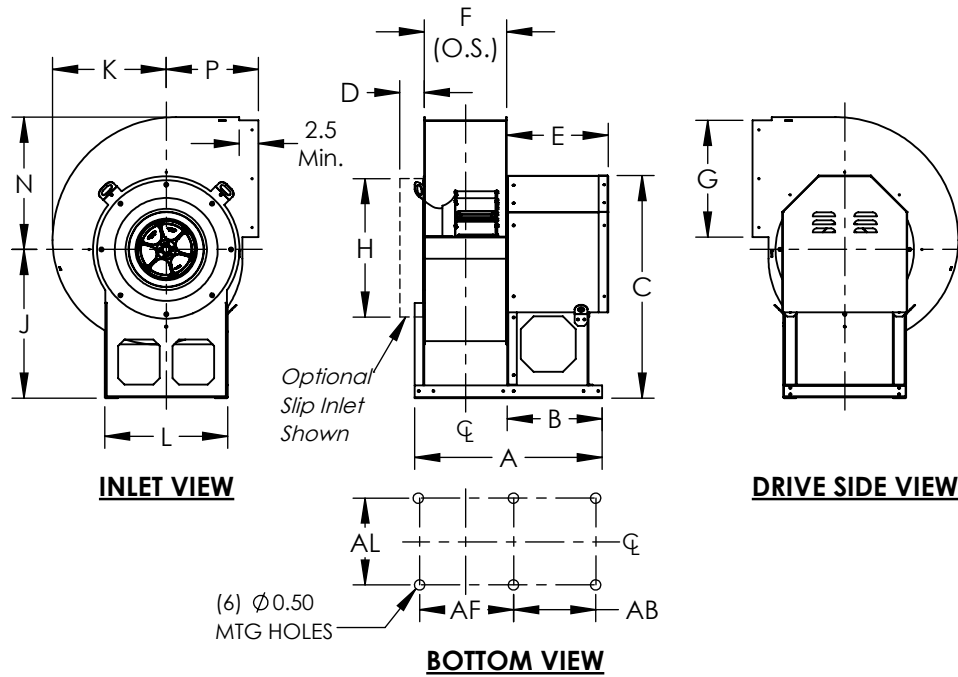

DATE: TAG:
 JOB:
 PROJECT:
 COMPANY:
 SALES PERSON:

UVS1 CLASS 0 ARRANGEMENT 4
 UTILITY VENT SET



STANDARD CONSTRUCTION:

1. Welded Housing
2. Aluminum Wheel
3. Galvanized and Bolted Pedestal
4. Slip Outlet
5. Open Inlet
6. Motors: Premium Efficient & GPlus

OPTIONAL ACCESSORIES:

1. Weather/Motor Cover (shown in illustration)
2. Slip and Flanged Inlet
3. Inlet/Outlet Companion Flange
4. Flanged Outlet
5. Vibration Isolators
6. Vibration Rails
7. Shaft Seal
8. Inlet Wire Guard
9. Outlet Screen
9. Piezo Ring
10. Pressure Transducer
11. Disconnect Switch

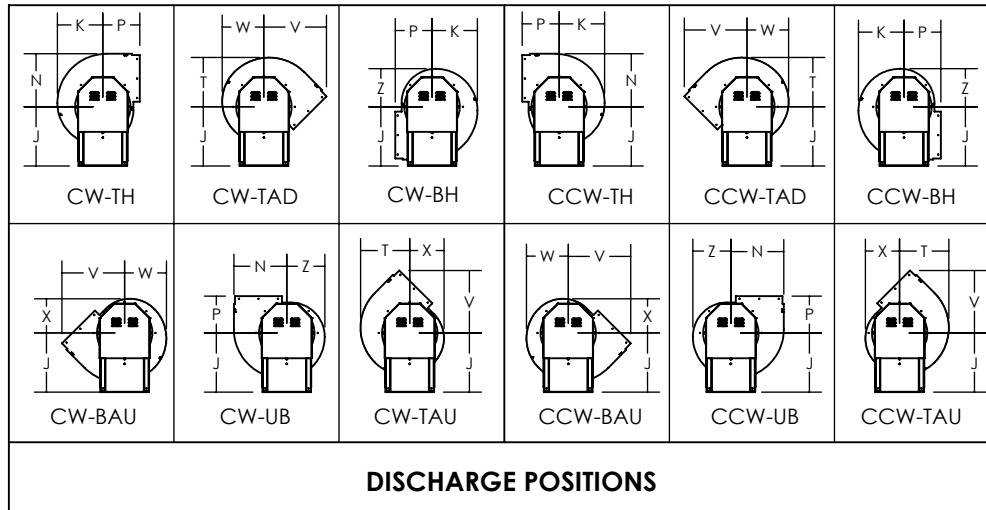

DIMENSIONAL DATA

Size	A	B	C	D	E	F	G	H	J	K	L	N	P	T	V	W	X	Z	AB	AF	AL	WT. (lbs)	MAX. RPM	MAX. MTR
60	22.75	14.06	25.25	3.19	14.88	7.06	10.00	14.13	18.13	9.94	15.75	11.56	11.75	10.76	16.13	9.16	7.88	8.38	12.56	8.63	13.69	70	2680	56
70	22.75	14.06	25.25	3.19	14.88	7.06	10.00	14.13	18.13	9.94	15.75	11.56	11.75	10.76	16.13	9.16	7.88	8.38	12.56	8.63	13.69	70	2680	56
80	22.75	14.06	25.25	3.19	15.63	7.06	10.00	14.13	18.13	9.94	15.75	11.56	11.75	10.76	16.13	9.16	7.88	8.38	12.56	8.63	13.69	70	2680	56
100	22.75	14.06	25.25	3.19	15.63	7.06	10.00	14.13	18.13	9.94	15.75	11.56	11.75	10.76	16.13	9.16	7.88	8.38	12.56	8.63	13.69	68	2680	56
122	24.31	14.06	26.38	3.19	15.63	8.63	12.25	16.39	18.13	12.06	17.75	14.06	13.19	13.06	18.88	11.13	9.13	10.13	12.56	10.19	15.69	84	2600	145T
135	25.94	14.81	27.00	3.19	15.63	9.50	13.50	17.63	18.13	13.25	19.25	15.44	13.94	14.31	20.44	12.19	10.00	11.13	13.31	11.06	17.19	94	2332	145T
150	27.00	14.81	29.38	3.19	15.63	10.56	15.00	19.13	19.75	14.69	19.25	17.06	14.38	15.88	21.88	13.50	11.06	12.31	13.31	12.13	17.19	107	2099	145T
165	28.06	14.81	32.06	3.19	15.63	11.63	16.50	21.19	21.38	16.13	19.25	18.75	14.31	17.44	23.06	14.75	12.13	13.44	13.31	13.19	17.19	119	2000	184T
182	29.31	14.81	34.75	3.19	15.63	12.88	18.25	22.89	23.25	17.75	19.25	20.69	14.44	19.19	24.44	16.31	13.38	14.81	13.31	14.44	17.19	134	1670	184T
200	30.56	14.81	37.63	3.69	15.63	14.13	20.00	24.63	25.25	19.44	20.50	22.63	15.50	21.00	26.63	17.81	14.63	16.19	13.31	15.69	18.44	166	1434	184T
222	33.63	16.31	41.56	3.69	17.13	15.69	22.25	27.44	27.75	21.56	22.75	25.13	16.94	23.31	29.38	19.75	16.19	18.00	14.81	17.25	20.69	200	1429	215T
245	35.19	16.31	45.06	3.69	17.13	17.25	24.50	29.44	30.25	23.69	23.50	27.56	18.31	25.63	32.13	21.69	17.81	19.75	14.81	18.81	21.44	239	1388	215T
270	37.00	16.31	49.06	3.69	17.13	19.06	27.00	31.94	33.00	26.06	25.00	30.38	19.88	28.19	35.19	23.88	19.56	21.69	14.81	20.63	22.94	280	1138	215T

ALL DIMENSIONS ARE IN INCHES, WEIGHTS ARE APPROXIMATE AND DOES NOT INCLUDE DRIVES OR ACCESSORIES.

REVISION: _____ FORM: _____ REPLACES: _____